

ECI-100

INSTALLATION INSTRUCTIONS

English (EN)

Date: 10-2015

Document number: 87202-3

© 2015 Raymarine UK Limited

Raymarine[®]
BY  **FLIR**



Trademark and patents notice

Raymarine, Tacktick, Clear Pulse, Truzoom, HSB, SeaTalk, SeaTalk^{hs}, SeaTalk^{ng}, Micronet, Raytech, Gear Up, Marine Shield, Seahawk, Autohelm, Automagic, and Visionality are registered or claimed trademarks of Raymarine Belgium.

FLIR, DownVision, SideVision, Dragonfly, Quantum, Instalert, Infrared Everywhere, and The World's Sixth Sense are registered or claimed trademarks of FLIR Systems, Inc.

All other trademarks, trade names, or company names referenced herein are used for identification only and are the property of their respective owners.

This product is protected by patents, design patents, patents pending, or design patents pending.

Fair Use Statement

You may print no more than three copies of this manual for your own use. You may not make any further copies or distribute or use the manual in any other way including without limitation exploiting the manual commercially or giving or selling copies to third parties.

Software updates

Important: Check the Raymarine website for the latest software releases for your product.

www.raymarine.com/software

Product handbooks

The latest versions of all English and translated handbooks are available to download in PDF format from the website www.raymarine.com. Please check the website to ensure you have the latest handbooks.

Copyright ©2015 Raymarine UK Ltd. All rights reserved.





Contents

Chapter 1 Important information.....	7	Chapter 8 Technical support	45
Water ingress	7	8.1 Raymarine product support and servicing	46
Disclaimer	7	8.2 Viewing product information	47
EMC installation guidelines	7	Chapter 9 Technical specification.....	49
Suppression ferrites	8	9.1 Technical specification.....	50
Connections to other equipment	8	Chapter 10 Spares and accessories	51
Declaration of conformity.....	8	10.1 Spares and accessories.....	52
Product disposal.....	8	10.2 SeaTalk ^{ng} ® cables and accessories	52
Warranty registration.....	8	Appendix A Supported J1939 and NMEA	
IMO and SOLAS.....	8	2000 sentences	55
Technical accuracy	8		
Chapter 2 Document and product information.....	9		
2.1 Document information	10		
2.2 Product overview	11		
Chapter 3 Planning the installation	13		
3.1 Installation checklist	14		
3.2 Parts supplied	14		
3.3 Required additional components	15		
3.4 Compatible displays	15		
3.5 Compatible autopilot systems	16		
3.6 Software updates	16		
3.7 Tools required	17		
3.8 Typical systems	17		
3.9 Warnings and cautions	19		
3.10 General location requirements	19		
3.11 Product dimensions	20		
Chapter 4 Cables and connections.....	21		
4.1 General cabling guidance	22		
4.2 Connections overview	22		
4.3 Power connection	23		
4.4 Volvo engine connections	25		
4.5 Yamaha engine connections	27		
4.6 Yanmar engine connections.....	28		
4.7 Honda engine connections	29		
4.8 Caterpillar (CAT) engine connections.....	30		
Chapter 5 Mounting.....	31		
5.1 Mounting the unit	32		
Chapter 6 System checks and troubleshooting	33		
6.1 Initial power on test	34		
6.2 Engine identification and setup - LightHouse™ MFDs.....	35		
6.3 Engine identification and setup — Legacy MFDs and Instrument Displays.....	37		
6.4 Troubleshooting	39		
Chapter 7 Maintenance	43		
7.1 Routine checks	44		
7.2 Unit cleaning instructions	44		



Chapter 1: Important information

Water ingress



Warning: Product installation and operation

- This product must be installed and operated in accordance with the instructions provided. Failure to do so could result in personal injury, damage to your vessel and/or poor product performance.
- Raymarine recommends certified installation by a Raymarine approved installer. A certified installation qualifies for enhanced product warranty benefits. Contact your Raymarine dealer for further details, and refer to the separate warranty document packed with your product.



Warning: Product grounding

Before applying power to this product, ensure it has been correctly grounded, in accordance with the instructions provided.



Warning: Positive ground systems

Do not connect this unit to a system which has positive grounding.



Warning: Power supply voltage

Connecting this product to a voltage supply greater than the specified maximum rating may cause permanent damage to the unit. Refer to the *Technical specification* section for voltage rating.



Warning: Switch off power supply

Ensure the vessel's power supply is switched OFF before starting to install this product. Do NOT connect or disconnect equipment with the power switched on, unless instructed in this document.

Caution: Power supply protection

When installing this product ensure the power source is adequately protected by means of a suitably-rated fuse or automatic circuit breaker.

Caution: Service and maintenance

This product contains no user serviceable components. Please refer all maintenance and repair to authorized Raymarine dealers. Unauthorized repair may affect your warranty.

Water ingress disclaimer

Although the waterproof rating capacity of this product meets the stated IPX standard (refer to the product's *Technical Specification*), water intrusion and subsequent equipment failure may occur if the product is subjected to commercial high-pressure washing. Raymarine will not warrant products subjected to high-pressure washing.

Disclaimer

Raymarine does not warrant that this product is error-free or that it is compatible with products manufactured by any person or entity other than Raymarine.

Raymarine is not responsible for damages or injuries caused by your use or inability to use the product, by the interaction of the product with products manufactured by others, or by errors in information utilized by the product supplied by third parties.

EMC installation guidelines

Raymarine equipment and accessories conform to the appropriate Electromagnetic Compatibility (EMC) regulations, to minimize electromagnetic interference between equipment and minimize the effect such interference could have on the performance of your system

Correct installation is required to ensure that EMC performance is not compromised.

Note: In areas of extreme EMC interference, some slight interference may be noticed on the product. Where this occurs the product and the source of the interference should be separated by a greater distance.

For **optimum** EMC performance we recommend that wherever possible:

- Raymarine equipment and cables connected to it are:
 - At least 1 m (3 ft) from any equipment transmitting or cables carrying radio signals e.g. VHF radios, cables and antennas. In the case of SSB radios, the distance should be increased to 7 ft (2 m).
 - More than 2 m (7 ft) from the path of a radar beam. A radar beam can normally be assumed to spread 20 degrees above and below the radiating element.
- The product is supplied from a separate battery from that used for engine start. This is important to prevent erratic behavior and data loss which can occur if the engine start does not have a separate battery.
- Raymarine specified cables are used.
- Cables are not cut or extended, unless doing so is detailed in the installation manual.

Note: Where constraints on the installation prevent any of the above recommendations, always ensure the maximum possible separation between different items of electrical equipment, to provide the best conditions for EMC performance throughout the installation

of the unit. You will need this serial number when registering your product online. You should retain the label for future reference.

IMO and SOLAS

The equipment described within this document is intended for use on leisure marine boats and workboats NOT covered by International Maritime Organization (IMO) and Safety of Life at Sea (SOLAS) Carriage Regulations.

Technical accuracy

To the best of our knowledge, the information in this document was correct at the time it was produced. However, Raymarine cannot accept liability for any inaccuracies or omissions it may contain. In addition, our policy of continuous product improvement may change specifications without notice. As a result, Raymarine cannot accept liability for any differences between the product and this document. Please check the Raymarine website (www.raymarine.com) to ensure you have the most up-to-date version(s) of the documentation for your product.

Suppression ferrites

- Raymarine cables may be pre-fitted or supplied with suppression ferrites. These are important for correct EMC performance. If ferrites are supplied separately to the cables (i.e. not pre-fitted), you must fit the supplied ferrites, using the supplied instructions.
- If a ferrite has to be removed for any purpose (e.g. installation or maintenance), it must be replaced in the original position before the product is used.
- Use only ferrites of the correct type, supplied by Raymarine or its authorized dealers.
- Where an installation requires multiple ferrites to be added to a cable, additional cable clips should be used to prevent stress on the connectors due to the extra weight of the cable.

Connections to other equipment

Requirement for ferrites on non-Raymarine cables

If your Raymarine equipment is to be connected to other equipment using a cable not supplied by Raymarine, a suppression ferrite **MUST** always be attached to the cable near the Raymarine unit.

Declaration of conformity

Raymarine UK Ltd. declares that this product is compliant with the essential requirements of EMC directive 2004/108/EC.

The original Declaration of Conformity certificate may be viewed on the relevant product page at www.raymarine.com.

Product disposal

Dispose of this product in accordance with the WEEE Directive.



The Waste Electrical and Electronic Equipment (WEEE) Directive requires the recycling of waste electrical and electronic equipment.

Warranty registration

To register your Raymarine product ownership, please visit www.raymarine.com and register online.

It is important that you register your product to receive full warranty benefits. Your unit package includes a bar code label indicating the serial number

Chapter 2: Document and product information

Chapter contents

- [2.1 Document information on page 10](#)
- [2.2 Product overview on page 11](#)



2.1 Document information

This document contains important information related to the installation of your Raymarine product.

The document includes information to help you:

- plan your installation and ensure you have all the necessary equipment;
- install and connect your product as part of a wider system of connected marine electronics;
- troubleshoot problems and obtain technical support if required.

This and other Raymarine product documents are available to download in PDF format from www.raymarine.com.

Note:

- Accepted methods of payment for printed manuals are credit cards and PayPal.
- Printed manuals can be shipped worldwide.
- Further manuals will be added to the Print Shop over the coming months for both new and legacy products.
- Raymarine user manuals are also available to download free-of-charge from the Raymarine website, in the popular PDF format. These PDF files can be viewed on a PC / laptop, tablet, smartphone, or on the latest generation of Raymarine multifunction displays.

Applicable products

This document is applicable to the following products:

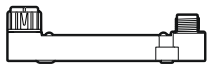
	Part number	Name	Description
	E70227	ECI-100	Engine & Control Interface

Document illustrations

Your product may differ slightly from that shown in the illustrations in this document, depending on product variant and date of manufacture.

All images are provided for illustration purposes only.

Product documentation

The following documentation is applicable to your product:

Description	Part number
ECI-100 Installation instructions Installation of an ECI-100 unit and connection to a wider system of marine electronics.	88026 / 87202
SeaTalk^{ng} Reference manual Details the planning and operation of systems based on the SeaTalk ^{ng} network.	81300
LightHouseTM MFD operation instructions Details the operation of the Data application and autopilot integration for all LightHouse TM powered MFDs.	81360

User manuals Print Shop

Raymarine provides a Print Shop service, enabling you to purchase a high-quality, professionally-printed manual for your Raymarine product.

Printed manuals are ideal for keeping onboard your vessel, as a useful source of reference whenever you need assistance with your Raymarine product.

Visit <http://www.raymarine.co.uk/view/?id=5175> to order a printed manual, delivered directly to your door.

For further information about the Print Shop, please visit the Print Shop FAQ pages: <http://www.raymarine.co.uk/view/?id=5751>.

2.2 Product overview

The unit connects to a **SeaTalk^{ng}**® backbone and to an engine's controller area network (CAN bus). Supported **J1939** and **NMEA 2000** engine and transmission data and steering control messages are converted and then transmitted on to the **SeaTalk^{ng}**® backbone; Enabling engine data transmission and steering control.



The **ECI-100** can be used as an engine interface and a steering control interface.

The product includes the following features:

Engine interface

- Attaches directly to supported engines' CAN bus.
- Receives engine and transmission data, warnings, faults and alarms from the engine's CAN bus and transmits them on **SeaTalk^{ng}**®

Steering control

- Attaches directly to supported 'drive-by-wire' steering control systems.
- Receives steering messages from a connected **EV2 Evolution™** autopilot and transmits on the third party steering control system.
- Receives feedback from the steering control system and transmits on **SeaTalk^{ng}**®.

The **ECI-100** provides electrical Isolation between the third party CAN bus and **SeaTalk^{ng}**®.

Supported engines / steering systems

The unit can be used to connect directly into a compatible engine's CAN bus, which use the **J1939** and / or **NMEA 2000** standard and drive-by-wire steering control systems, used by many marine engine manufacturers including:

Supported engine systems

- Volvo Penta Electronic Vessel Control (EVC) systems
- Yamaha Marine Command Link
- Yamaha Marine Command Link Plus
- Yanmar engine systems
- Honda engines
- Caterpillar engine systems (must include MPD, MPD color or mini MPD)
- Other inboard, outboard and stern drive propulsion systems which use standard **J1939** or **NMEA 2000** protocols

Supported drive-by-wire steering systems

- Volvo Penta IPS

- Volvo Penta Aquamatic joystick control
- Yamaha Helm Master

Note: For the latest engine compatibility information please visit the Raymarine website www.raymarine.com.



Chapter 3: Planning the installation

Chapter contents

- 3.1 Installation checklist on page 14
- 3.2 Parts supplied on page 14
- 3.3 Required additional components on page 15
- 3.4 Compatible displays on page 15
- 3.5 Compatible autopilot systems on page 16
- 3.6 Software updates on page 16
- 3.7 Tools required on page 17
- 3.8 Typical systems on page 17
- 3.9 Warnings and cautions on page 19
- 3.10 General location requirements on page 19
- 3.11 Product dimensions on page 20



3.1 Installation checklist

Installation includes the following activities:

Installation Task	
1	Plan your system.
2	Obtain all required equipment and tools.
3	Site all equipment.
4	Route all cables.
5	Drill cable and mounting holes.
6	Make all connections into equipment.
7	Secure all equipment in place.
8	Power on and test the system.



Schematic diagram

A schematic diagram is an essential part of planning any installation. It is also useful for any future additions or maintenance of the system. The diagram should include:

- Location of all components.
- Connectors, cable types, routes and lengths.

3.2 Parts supplied

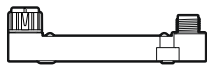
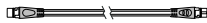
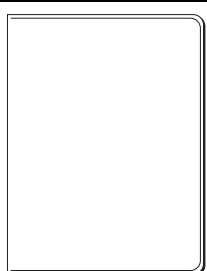
The following items are supplied with your product.

Item	Description	Quantity
	ECI-100 (Engine & Control Interface)	1
	400 mm (1.3 ft) SeaTalk ^{ng} spur cable (A06038)	1
	Document pack	1
	Mounting screws	2



3.3 Required additional components



This product forms part of a system of electronics and requires the following additional components for full operation.

- Engine specific adaptor cables are required to connect your unit to the engine(s) CAN bus. Refer to [Chapter 10 Spares and accessories](#) for suitable adaptor cables.
- To enable steering control a compatible autopilot is required. Refer to [3.5 Compatible autopilot systems](#) for a list of compatible products.
- To display engine data a compatible display is required. Refer to [3.4 Compatible displays](#) for a list of compatible products.

3.4 Compatible displays

This product is compatible with the following display products.

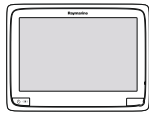
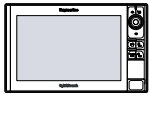
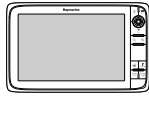
LightHouse™ MFDs:

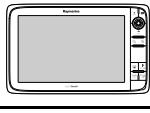
	Product variants		Product variants
	a Series		eS Series
	c Series		gS Series
	e Series		

Correct operation requires **LightHouse™** MFDs to be running **LightHouse™** Release 8.52 or greater.

Instrument Displays

	Product variants
	i70

- Operation is limited to the PGNs supported by the Instrument display.
- Instrument displays should be running the latest available software.

Legacy MFDs

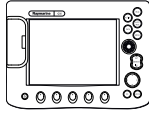
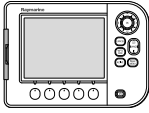
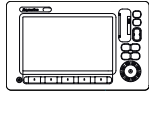
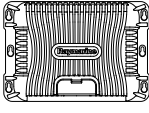
	Product variants		Product variants
	C-Series Classic C70, C80, C120		A-Series Classic A50, A50D, A57D, A70, A70D
	E-Series Classic E80, E120		
	C-Series Widescreen C90W, C120W, C140W		G-Series GPM400
	E-Series Widescreen E90W, E120W, E140W		

Note:

- Operation is limited to the PGNs supported by the Legacy MFD.
- Legacy MFDs must be running the latest available software.

3.5 Compatible autopilot systems

For steering control this product is compatible with the following Raymarine autopilots.

- EV2 — Evolution™ autopilot

3.6 Software updates

The software running on the product can be updated.

- Raymarine periodically releases software updates to improve product performance and add new features.
- You can update the software for your product using a connected and compatible multifunction display.
- Refer to www.raymarine.com/software/ for the latest software updates and the software update procedure for your product.
- If in doubt as to the correct procedure for updating your product software, refer to your dealer or Raymarine technical support.

Caution: Installing software updates

The software update process is carried out at your own risk. Before initiating the update process ensure you have backed up any important files.

Ensure that the unit has a reliable power supply and that the update process is not interrupted.

Damage caused by incomplete updates are not covered by Raymarine warranty.

By downloading the software update package, you agree to these terms.



3.7 Tools required

Product installation requires the following tools:

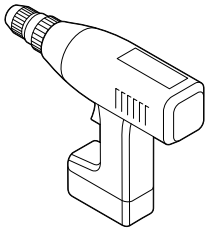
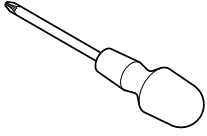
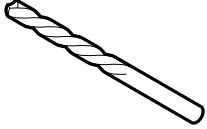
Item	Description	Quantity
	Power drill	1
	Pozidrive screwdriver	1
	Drill bit of appropriate size*	1

Note: * The appropriate drill bit size is dependent on the thickness and material of the mounting surface.

3.8 Typical systems

Important:

- The **ECI-100** should NOT be connected to the same engine CAN bus as other 3rd party gateway products. The **ECI-100** should be used to replace existing gateway products in your system.
- Do NOT connect 2 or more **ECI-100** units to the same engine CAN bus.

Example: basic system — engine interface only

In the example below the unit is used as an engine interface only, the unit will interface with all engines on the same CAN bus. In this configuration the unit cannot control the vessel's steering system.

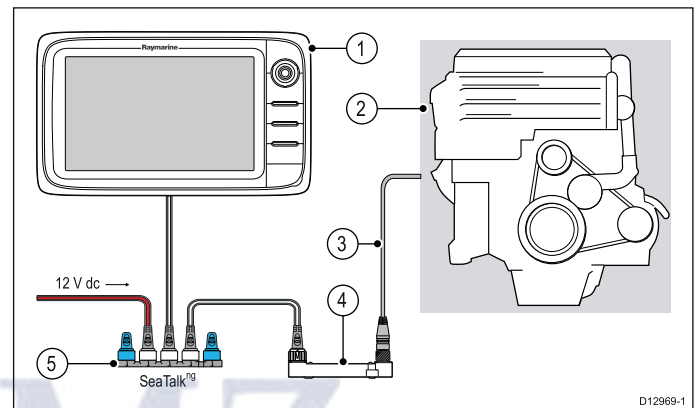

Note: The illustration above shows the various products that can be connected in a typical system. For information on how to connect the products, refer to the [Chapter 4 Cables and connections](#) section. For information on available cables and accessories, refer to the [Chapter 10 Spares and accessories](#) section.

Item	Description
1	Multifunction display
2	Vessel engine(s) (Connection to engine's CAN bus)
3	Engine-specific adaptor cable
4	ECI unit
5	SeaTalk ^{ng} 5-way block

Example: Independent engine CAN bus networks

Unless instructed otherwise, generally on a multi-engine vessel that has a dedicated CAN bus network for each engine, 1 **ECI-100** per network is required.

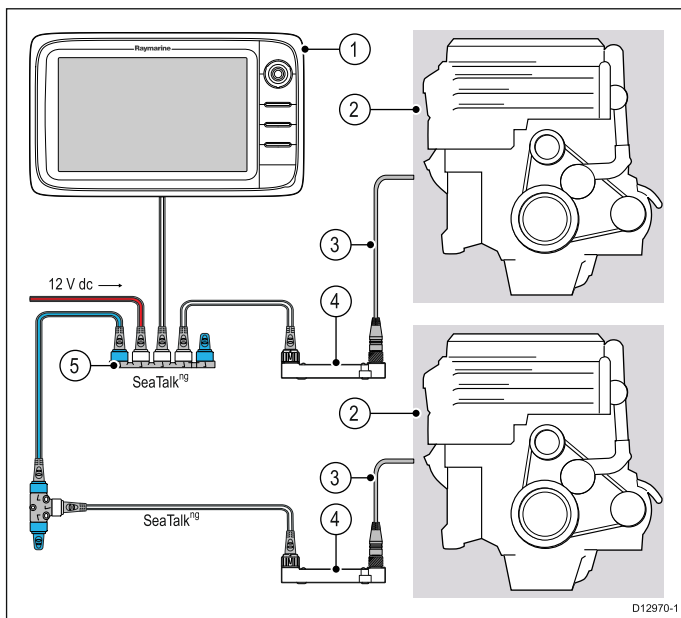

Note: The illustration above shows the various products that can be connected in a typical system. For information on how to connect the products, refer to the [Chapter 4 Cables and connections](#) section. For information on available cables and accessories, refer to the [Chapter 10 Spares and accessories](#) section.

Item	Description
1	Multifunction display
2	Vessel engine(s) and steering (Connection to engine CAN bus)
3	Engine-specific adaptor cable
4	ECI unit
5	SeaTalk ^{ng} 5-way block
6	EV2 — Evolution™ autopilot
7	SeaTalk ^{ng} Pilot control head
8	SeaTalk ^{ng} instrument display
9	SeaTalk ^{ng} spur cable connection between the SeaTalk ^{ng} bus and the EV2's SeaTalk ^{ng} connector.

Note: The illustration above shows the various products that can be connected in a typical system. For information on how to connect the products, refer to the [Chapter 4 Cables and connections](#) section. For information on available cables and accessories, refer to the [Chapter 10 Spares and accessories](#) section.

Item	Description
1	Multifunction display
2	Vessel engines (Connection to engine's CAN bus)
3	Engine specific adaptor cables
4	ECI units
5	SeaTalk ^{ng} 5-way block

Typical system — legacy MFDs

Example: basic system — engine interface only

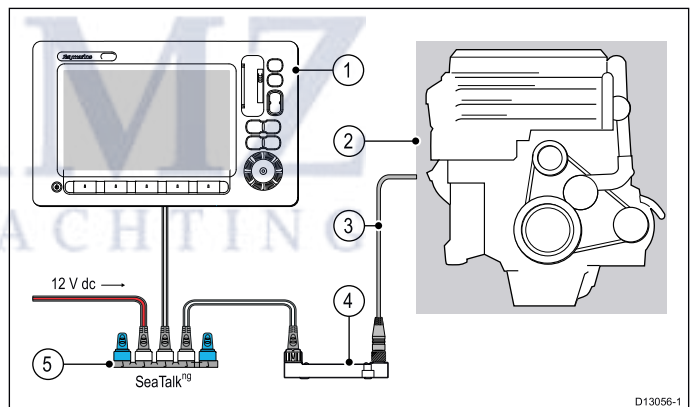

Example: expanded system

In the example below the unit is used as both engine interface and steering control interface simultaneously.

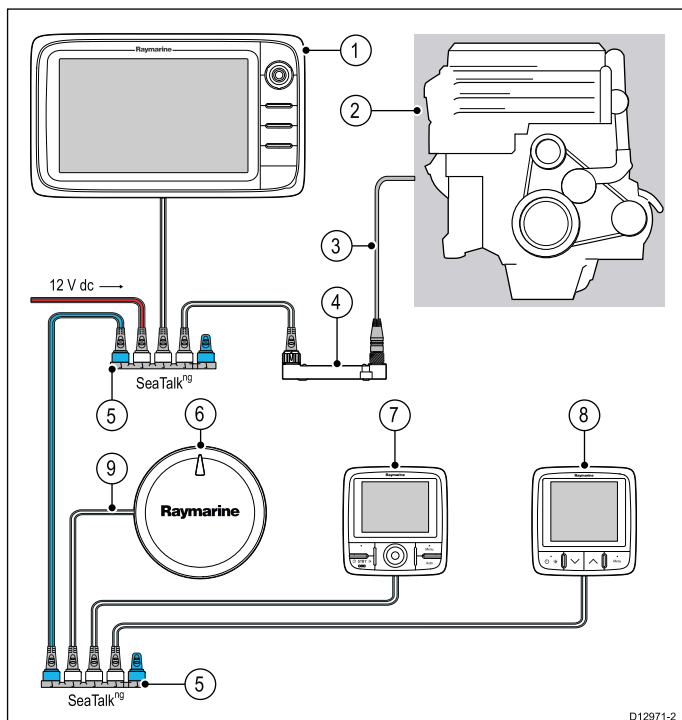

1. Legacy MFD (e.g. E-Series Widescreen).
2. Vessel engine(s), connected to engine CAN bus (e.g. J1939).
3. Engine-specific adaptor cable.
4. ECI unit.
5. SeaTalk^{ng} 5-way block.

3.9 Warnings and cautions

Important: Before proceeding, ensure that you have read and understood the warnings and cautions provided in the [Chapter 1 Important information](#) section of this document.

3.10 General location requirements

Important considerations when choosing a suitable location for your product.

This product is suitable for mounting below decks.

The product should be mounted where it will be:

- protected from physical damage and excessive vibration.
- well ventilated and away from heat sources.

When choosing a location for the product, consider the following points to ensure reliable and trouble-free operation:

- **Access** — there must be sufficient space to enable cable connections to the product, avoiding tight bends in the cable.
- **Diagnostics** — the product must be mounted in a location where the diagnostics LED is easily visible.

Note: Not all products include a diagnostics LED. Refer to the [Chapter 6 System checks and troubleshooting](#) for more information.

- **Electrical interference** — the product should be mounted far enough away from any equipment that may cause interference such as motors, generators and radio transmitters / receivers.
- **Magnetic compass** — refer to the *Compass safe distance* section in this document for advice on maintaining a suitable distance between this product and any compasses on your vessel.
- **Power** — to keep cable runs to a minimum, the product must be located as close as possible to the vessel's dc power supply.
- **Mounting surface** — ensure the product is adequately supported on a secure surface. Refer to the weight information provided in the *Technical specification* for this product and ensure that the intended mounting surface is suitable for bearing the product weight. Do NOT mount units or cut holes in places which may damage the structure of the vessel.

Compass safe distance

To prevent potential interference with the vessel's magnetic compasses, ensure an adequate distance is maintained from the product.

When choosing a suitable location for the product you should aim to maintain the maximum possible distance from any compasses. Typically this distance should be at least 1 m (3 ft) in all directions. However for some smaller vessels it may not be possible to locate the product this far away from a compass. In this situation, when choosing the installation location for your product, ensure that the compass is not affected by the product when it is in a powered state.

3.11 Product dimensions

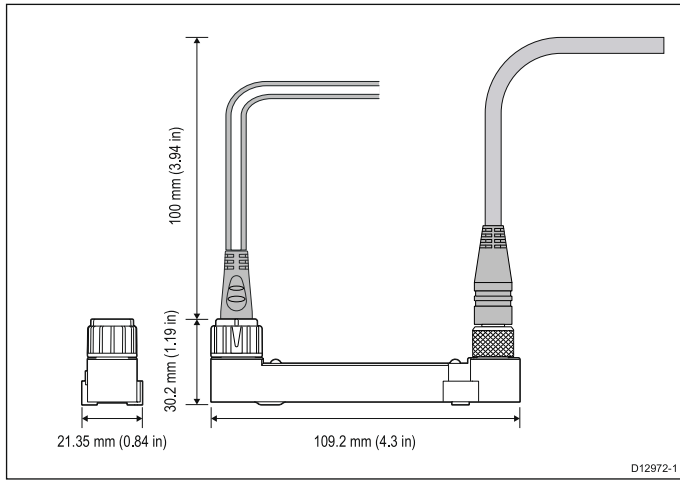

Chapter 4: Cables and connections

Chapter contents

- 4.1 General cabling guidance on page 22
- 4.2 Connections overview on page 22
- 4.3 Power connection on page 23
- 4.4 Volvo engine connections on page 25
- 4.5 Yamaha engine connections on page 27
- 4.6 Yanmar engine connections on page 28
- 4.7 Honda engine connections on page 29
- 4.8 Caterpillar (CAT) engine connections on page 30



4.1 General cabling guidance

Cable types and length

It is important to use cables of the appropriate type and length

- Unless otherwise stated use only standard cables of the correct type, supplied by Raymarine.
- Ensure that any non-Raymarine cables are of the correct quality and gauge. For example, longer power cable runs may require larger wire gauges to minimize voltage drop along the run.

Routing cables

Cables must be routed correctly, to maximize performance and prolong cable life.

- Do NOT bend cables excessively. Wherever possible, ensure a minimum bend diameter of 200 mm (8 in) / minimum bend radius of 100 mm (4 in).

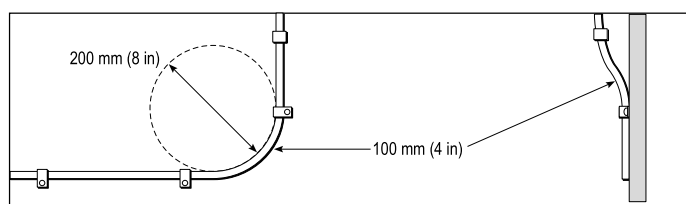

- Protect all cables from physical damage and exposure to heat. Use trunking or conduit where possible. Do NOT run cables through bilges or doorways, or close to moving or hot objects.
- Secure cables in place using tie-wraps or lacing twine. Coil any extra cable and tie it out of the way.
- Where a cable passes through an exposed bulkhead or deckhead, use a suitable watertight feed-through.
- Do NOT run cables near to engines or fluorescent lights.

Always route data cables as far away as possible from:

- other equipment and cables,
- high current carrying AC and DC power lines,
- antennae.

Strain relief

Ensure adequate strain relief is provided. Protect connectors from strain and ensure they will not pull out under extreme sea conditions.

Cable shielding

Ensure that all data cables are properly shielded that the cable shielding is intact (e.g. hasn't been scraped off by being squeezed through a tight area).

4.2 Connections overview

Use the following information to help you identify the connections on your product.

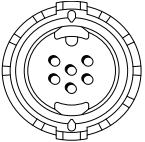
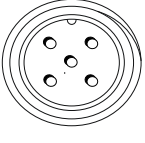
Connector	Connector	Connects to:	Suitable cables
	SeaTalk ^{ng}	SeaTalk ^{ng} using the supplied spur cable.	SeaTalk ^{ng} spur cables. Refer to Chapter 10 Spares and accessories .
	DeviceNet	Engine CAN bus.	Engine specific DeviceNet adaptor cable. Refer to Chapter 10 Spares and accessories .

Ensure that the DeviceNet connector's dust cap is removed before trying to make connections.

Making connections

Follow the steps below to connect the cable(s) to your product.

1. Ensure that the vessel's power supply is switched off.
2. Ensure that the device being connected to the unit has been installed in accordance with the installation instructions supplied with that device.
3. Ensuring correct orientation, push the cable connector fully onto the corresponding connector on the unit.
4. Turn the locking collar clockwise to secure the cable.

4.3 Power connection

Both connections need power to be supplied from each network i.e. The SeaTalk^{ng} connection is powered by the SeaTalk^{ng} backbone or Seataalk^{ng} device and the engine (DeviceNet) connection is powered from the engine's CAN bus network.

The information in this section relates to powering the SeaTalk^{ng} network. Power will already be available on your engines CAN bus to power the DeviceNet connection.

Please refer to the *Raymarine SeaTalk^{ng} Reference manual (81300)* for further information on SeaTalk^{ng} networks.

Power cable extension

The product is supplied with a power cable, which can be extended if required.

- The power cable for each unit in your system should be run as a separate, single length of 2-wire cable from the unit to the vessel's battery or distribution panel.
- Raymarine recommends a **minimum** wire gauge of 18AWG (0.82 mm²) for any length of cable extension.
- For all lengths of extension to the power cable, ensure there is a continuous **minimum** voltage at the product's power connector of 10.8 V with a fully flat battery at 11 V.

Important: Be aware that some products in your system (such as sonar modules) can create voltage peaks at certain times, which may impact the voltage available to other products during the peaks.

Power distribution

Recommendations and best practice.

- The product is supplied with a power cable. Only use the power cable supplied with the product. Do NOT use a power cable designed for, or supplied with, a different product.
- Refer to the *Power connection* section for more information on how to identify the wires in your product's power cable, and where to connect them.
- See below for more information on implementation for some common power distribution scenarios.

Important: When planning and wiring, take into consideration other products in your system, some of which (e.g. sonar modules) may place large power demand peaks on the vessel's electrical system.

Note: The information provided below is for guidance only, to help protect your product. It covers common vessel power arrangements, but does NOT cover every scenario. If you are unsure how to provide the correct level of protection, please consult an authorized Raymarine dealer or a suitably qualified professional marine electrician.

Implementation — direct connection to battery

- The power cable supplied with your product may be connected directly to the vessel's battery, via a suitably rated fuse or breaker.
- The power cable supplied with your product may NOT include a separate drain wire. If this is the case, only the power cable's red and black wires need to be connected.
- If the supplied power cable is NOT fitted with an inline fuse, you MUST fit a suitably rated fuse or breaker between the red wire and the battery's positive terminal.
- Refer to the inline fuse ratings provided in the product's documentation.
- If you need to extend the length of the power cable supplied with your product, ensure you observe the dedicated *Power cable extensions* advice provided in the product's documentation.

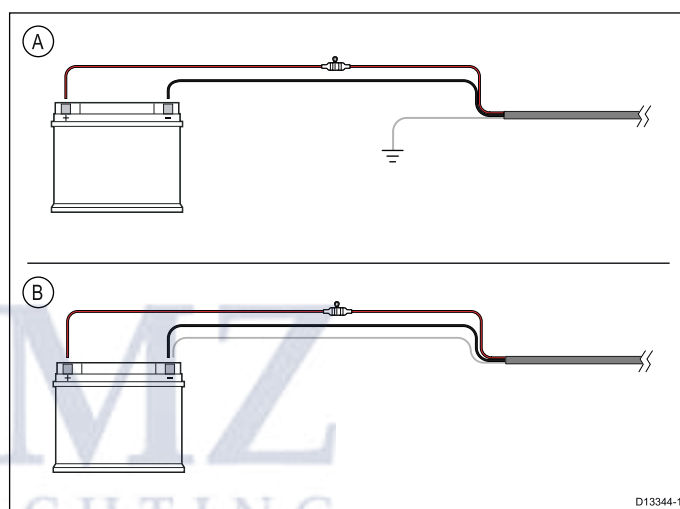

A	Battery connection scenario A: suitable for a vessel with a common RF ground point. In this scenario, if your product's power cable is supplied with a separate drain wire then it should be connected to the vessel's common ground point.
B	Battery connection scenario B: suitable for a vessel without a common grounding point. In this case, if your product's power cable is supplied with a separate drain wire then it should be connected directly to the battery's negative terminal.

Implementation — connection to distribution panel

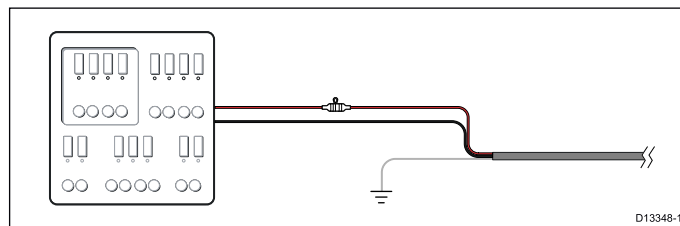

- Alternatively, the supplied power cable may be connected to a suitable breaker or switch on the vessel's distribution panel or factory-fitted power distribution point.
- The distribution point should be fed from the vessel's primary power source by 8 AWG (8.36 mm²) cable.

- Ideally, all equipment should be wired to individual suitably-rated thermal breakers or fuses, with appropriate circuit protection. Where this is not possible and more than 1 item of equipment shares a breaker, use individual in-line fuses for each power circuit to provide the necessary protection.
- In all cases, observe the recommended breaker / fuse ratings provided in the product's documentation.
- If you need to extend the length of the power cable supplied with your product, ensure you observe the dedicated *Power cable extensions* advice provided in the product's documentation.

Important: Be aware that the suitable fuse rating for the thermal breaker or fuse is dependent on the number of devices you are connecting.

Grounding

Ensure that you observe the separate grounding advice provided in the product's documentation.

More information

Raymarine recommends that best practice is observed in all vessel electrical installations, as detailed in the following standards:

- BMEA Code of Practice for Electrical and Electronic Installations in Boats
- NMEA 0400 Installation Standard
- ABYC E-11 AC & DC Electrical Systems on Boats
- ABYC A-31 Battery chargers and Inverters
- ABYC TE-4 Lightning Protection

Breakers, fuses and circuit protection

The information below is provided as guidance to help protect your product. The example illustrations provided are for common vessel power arrangements, if you are unsure how to provide the correct level of protection then please consult a Raymarine authorized dealer for support.

Distribution panel connection

It is recommended that your product is wired through your vessel's distribution panel via a thermal breaker or fuse.

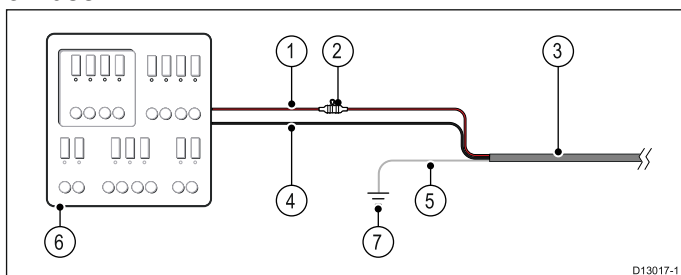

1. Vessel power supply positive (+)
2. In-line fuse (your product may contain a fuse already built in to the power cable.)
3. Product power cable
4. Vessel power supply negative (-)
5. * Drain wire

6. Vessel distribution panel
7. * Vessel RF ground point connection

Note: * Only applicable to products that include a drain wire on the product's power cable.

Thermal breaker rating

5 A (if only connecting one device)

Battery connection with RF ground

If your vessel does not have a distribution panel then your product may be wired directly to the battery with the drain wire connected to the vessel's RF ground point.

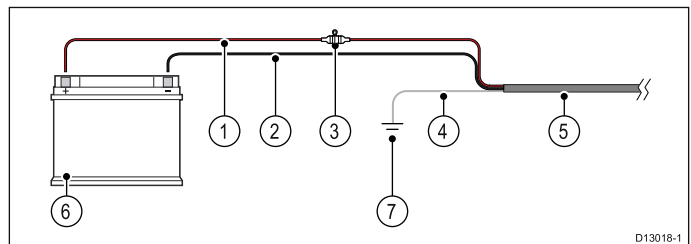

1. Vessel power supply positive (+)
2. Vessel power supply negative (-)
3. In-line fuse (If your products power cable does not have a built in fuse then an in-line fuse should be fitted.)
4. * Drain wire
5. Product power cable
6. Vessel battery
7. * Vessel RF ground point connection

Note: * Only applicable to products that include a drain wire on the product's power cable.

Battery connection with no RF ground

If your vessel does not have a distribution panel or an RF ground point then your product may be wired directly to the battery with the drain wire also connected to the battery's negative terminal.

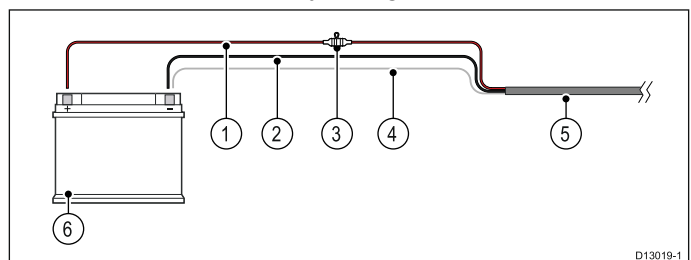

1. Vessel power supply positive (+)
2. Vessel power supply negative (-)
3. In-line fuse (If your products power cable does not have a built in fuse then an in-line fuse should be fitted.)
4. * Drain wire connected to vessel negative power supply.
5. Product power cable
6. Vessel battery

Note: * Only applicable to products that include a drain wire on the product's power cable.

Sharing a breaker

Where more than 1 piece of equipment shares a breaker you must provide protection for the individual circuits. E.g. by connecting an in-line fuse for each power circuit.

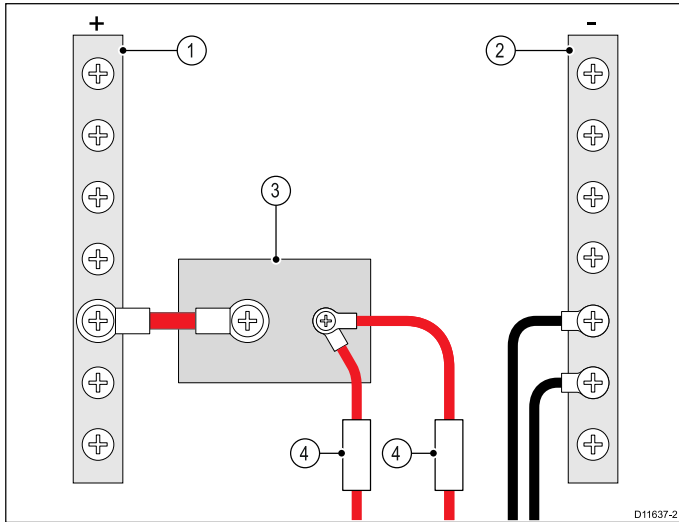

1	Positive (+) bar
2	Negative (-) bar
3	Circuit breaker
4	Fuse

Where possible, connect individual items of equipment to individual circuit breakers. Where this is not possible, use individual in-line fuses to provide the necessary protection.



Warning: Product grounding

Before applying power to this product, ensure it has been correctly grounded, in accordance with the instructions provided.

Grounding — Dedicated drain wire

The power cable supplied with this product includes a dedicated shield (drain) wire for connection to a vessel's RF ground point.

It is important that an effective RF ground is connected to the system. A single ground point should be used for all equipment. The unit can be grounded by connecting the shield (drain) wire of the power cable to the vessel's RF ground point. On vessels without an RF ground system the shield (drain) wire should be connected directly to the negative battery terminal.

The dc power system should be either:

- Negative grounded, with the negative battery terminal connected to the vessel's ground.
- Floating, with neither battery terminal connected to the vessel's ground



Warning: Positive ground systems

Do not connect this unit to a system which has positive grounding.

4.4 Volvo engine connections

The **ECI-100** can connect to compatible Volvo Penta engine Electronic Vessel Control (EVC) systems. The **ECI-100** enables engine data to be displayed on a **Raymarine®** MFD. In conjunction with an **EV2** autopilot the **ECI-100** allows full steering control of IPS and Aquamatic drive-by-wire steering control systems, without the need for a proprietary autopilot gateway.

Newer systems with a multi-link hub available

New and recent Volvo Penta engine EVC systems should have a multi-link hub available. The hub will have 6 connections, 1 of which must be available in order to connect the **ECI-100**.

Volvo link cable (E70240) is required. This cable must be connected to the **DeviceNet** connector on the **ECI-100** and an available connector on the Volvo Multi-link hub.

If a Volvo IPS or Aquamatic steering system is fitted then connecting an **EV2** as shown will also provide full drive-by-wire steering control.

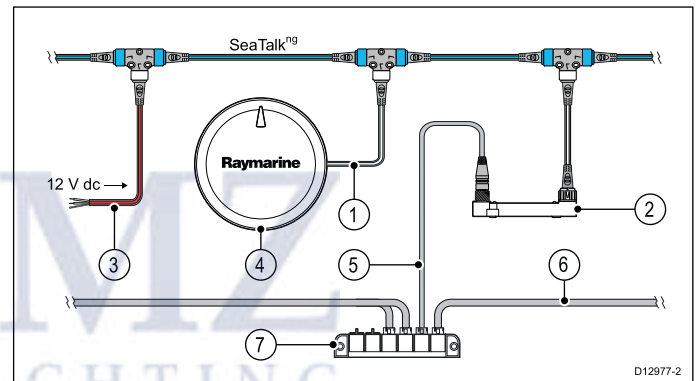

1. **SeaTalkng®** spur cable connection EV2 between the **SeaTalkng®** backbone and the EV2's **SeaTalkng®** connector.
2. **ECI-100** unit
3. **SeaTalkng®** backbone power supply (12 V dc)
4. **EV2 — Evolution™** autopilot (not required to display engine data)
5. Volvo link cable (E70240)
6. Volvo Penta engine system bus
7. Volvo Multi-link hub

Older systems with no multi-link hub available

On older systems where no multi-link hub is available, the Volvo Y-Loom splitter cable (E70241) must be used in conjunction with the Volvo link adaptor cable (E70240).

The Y-Loom cable must be connected inline in the Volvo Penta engine system bus, as shown and the Volvo link cable must be fitted to the Y-Loom cable and to the **DeviceNet** connector on the **ECI-100**.

If a Volvo IPS or Aquamatic steering system is fitted then connecting an **EV2** as shown will also provide full drive-by-wire steering control.

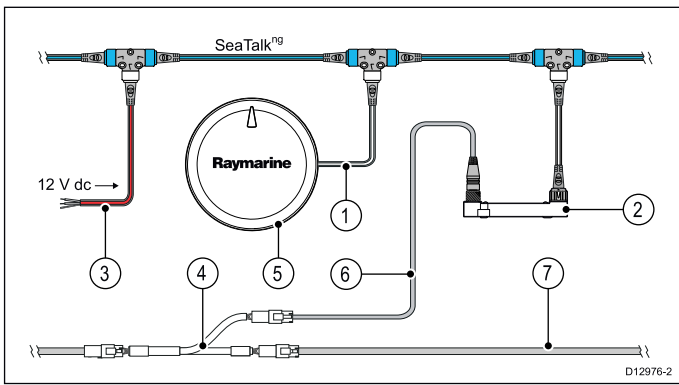

1. **SeaTalk^{ng}** spur cable connection between the **SeaTalk^{ng}** backbone and the EV2's **SeaTalk^{ng}** connector.
2. **ECI-100** unit
3. **SeaTalk^{ng}** backbone power supply (12 V dc)
4. Volvo Y-Loom splitter cable (E70241)
5. **EV2 — EvolutionTM** autopilot (not required to display engine data)
6. Volvo link cable (E70240)
7. Volvo Penta engine system bus

Note: Volvo and Volvo Penta are trademarks and/or registered trademarks of Volvo Trademark Holding AB. Raymarine is not affiliated with, or endorsed by Volvo.

Compatible Volvo systems

Compatible EVC systems

EVC-C	EVC-D
EVC-E	

Note: Not all engines have an EVC system fitted as standard. Please check to see if a compatible EVC is fitted to your system.

Compatible engines

Engine Data and Autopilot Steering Interface

D3 Aquamatic	IPS500
D4 Aquamatic	IPS550G
D6 Aquamatic	IPS600
V6 Aquamatic	IPS800
V8 Aquamatic	IPS900
IPS350	IPS1050
IPS400	IPS1200
IPS450	

Engine data only (Diesel engines which are EVC-equipped as standard)

D3	D11
D4	D12
D6	D13
D9	

Engine data only (only if the optional EVC system is fitted)

V6 Gasoline stern drive	D2 Sail drive
V8 Gasoline stern drive	D3 Sail drive
D1 Sail drive	D4–180 Sail drive

Volvo engine data and steering control

With the **ECI-100** connected to a compatible Volvo system the following engine data can be displayed on a **LightHouseTM** MFD. The **ECI-100** also enables access to full autopilot steering control, to an IPS or Aquamatic system.

Engine Data

Engine Speed (RPM)	Engine Boost Pressure ⁽¹⁾
Engine Hours	Battery Voltage
Engine Oil Temperature ⁽¹⁾	Transmission Oil Pressure ⁽¹⁾
Engine Coolant Temperature ⁽¹⁾	Transmission Oil Temperature ⁽¹⁾
Engine Oil Pressure ⁽¹⁾	Fuel Level ⁽¹⁾
Engine Coolant Pressure ⁽¹⁾	Boat Speed ⁽¹⁾
Engine Fuel Delivery Pressure ⁽¹⁾	Power Trim ⁽¹⁾
Engine Fuel Flow Rate	Rudder Angle (IPS systems only)

Note: ⁽¹⁾ Only available if relevant Volvo sensor is fitted.

Engine Alarms

Over Temperature	Low System Voltage
Low Oil Pressure	Low Coolant Level
Low Oil Level	Water In Fuel

4.5 Yamaha engine connections

The **ECI-100** can connect to compatible Yamaha outboard engine systems. One **ECI-100** unit is required for single or multiple outboard engines. Yamaha Command-Link and Command-Link Plus engine systems should have a hub available. The hub will have 6 connections, 1 of the 'DEVICE' connectors must be available in order to connect the **ECI-100**.

The Yamaha link cable (E70242) is required. This cable must be connected to the **DeviceNet** connector on the **ECI-100** and a spare 'DEVICE' connector on the hub.

If a Helm Master steering system is fitted then connecting an **EV2** as shown will also provide full Drive-By-Wire steering control.

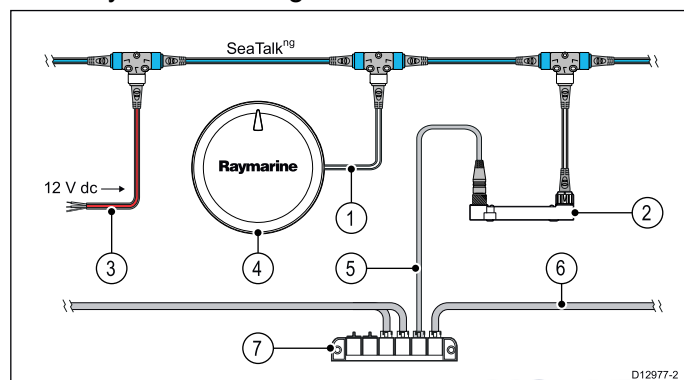

1. **SeaTalkng®** spur cable connection between the **SeaTalkng®** backbone and the EV2's **SeaTalkng®** connector.
2. **ECI-100** unit
3. **SeaTalkng®** backbone power supply (12 V dc)
4. **EV2 — Evolution™** autopilot (not required to display engine data)
5. Yamaha link cable (E70242)
6. Yamaha outboard engine system bus
7. Yamaha Command-Link or Command-Link Plus hub

Compatible Yamaha systems

Compatible Yamaha outboard control systems

Command-Link
Command-Link Plus
Helm Master

Note: Not all engines have a Command-Link or Command-Link Plus or Helm Master systems fitted as standard. Please ensure you have compatible system and engine fitted to your vessel before installing your ECI-100. Check with your local engine dealer if you are unsure.

Compatible engines

Engine Data only (when compatible engine system is fitted)

F50	F350	T60
F60	LF115	VZ150

F75	LF150	VZ225
F90	LF200	VZ250
F115	LF250	VZ300
F150	LZ150	Z150
F200	LZ200	Z175
F225	LZ250	Z200
F250	LZ300	Z250
F300	T50	Z300

Yamaha engine data and steering control

With the **ECI-100** connected to a compatible Yamaha outboard engine system the following engine data can be displayed on a **LightHouse™** MFD. The **ECI-100** also enables access to full autopilot steering control, to a Helm Master steering control system.

Engine Data

Engine Speed (RPM)	Transmission Gear Status
Engine Hours	Battery Voltage
Engine Coolant Temperature	Transmission Oil Pressure
Engine Oil Pressure	Transmission Oil Temperature
Engine Coolant Pressure	Fuel Level
Engine Fuel Flow Rate	Power Trim
Engine Boost Pressure	

Engine Alarms

Over Temperature	Low System Voltage
Low Oil Pressure	Low Fuel Pressure
Low Oil Level	Water In Fuel

4.6 Yanmar engine connections

The **ECI-100** can connect to compatible Yanmar engine and control systems. The **ECI-100** enables engine data to be displayed on a **Raymarine® MFD**.

A **DeviceNet** cable and T-Piece connector is required. The T-Piece connector must be connected inline with the existing **J1939** bus and the cable should be connected to the T-Piece and to the **DeviceNet** connector on the **ECI-100**.

Note: **DeviceNet** cables and accessories are available from your local Marine electronics Dealer / Retailer.

Single engine connection

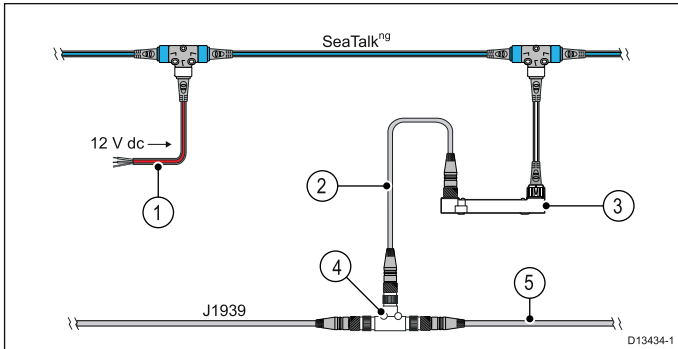

1. **SeaTalkng®** backbone power supply (12 V dc)
2. **DeviceNet** cable
3. **ECI-100** unit
4. **DeviceNet** T-Piece connector
5. **J1939** engine system bus

Multi-engine connection

On multi-engine systems the engines' **J1939** CAN bus networks and the **ECI-100** must all be connected to a separate **NMEA 2000** network. This network may already be available, otherwise one should be created using **DeviceNet** cables and connectors as shown below.

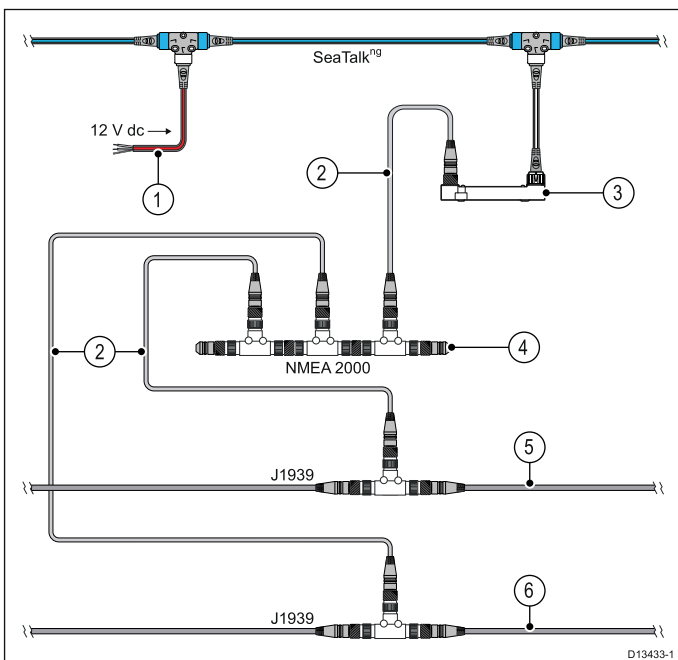

1. **SeaTalkng®** backbone power supply (12 V dc)

2. **DeviceNet** cable
3. **ECI-100**
4. **NMEA 2000** network
5. Engine 1 **J1939** network
6. Engine 2 **J1939** network

Compatible Yanmar systems

Compatible engines

Note: Please ensure you have compatible engine pre-installed with a **NMEA 2000** system fitted to your vessel before installing your **ECI-100**. Check with your local engine dealer if you are unsure.

Engine data only

4BY3-150	4JH80C
4BY3-150Z	4JH110
4BY3-180	6BY3-260
4BY3-180Z	6BY3-260Z
4BY3-220	6LY3-ETP
4BY3-220Z	6LY3-STP
4JH45	6LY3-UTP
4JH45C	8LV320
4JH57	8LV320Z
4JH57C	8LV370
4JH80	8LV370Z

Yanmar engine data

With the **ECI-100** connected to a compatible Yanmar engine system the following engine data can be displayed on a **LightHouse™ MFD**.

Engine Data

Engine Speed (RPM)	Engine Fuel Flow Rate
Engine Hours	Engine Boost Pressure
Engine Oil Temperature	Battery Voltage
Engine Coolant Temperature	Transmission Oil Pressure
Engine Oil Pressure	Transmission Oil Temperature
Engine Coolant Pressure	Fuel Level
Engine Fuel Delivery Pressure	

Engine Alarms

Over Temperature	Low System Voltage
Low Oil Pressure	Low Coolant Level
Low Oil Level	Water In Fuel

4.7 Honda engine connections

The **ECI-100** can connect to compatible Honda engine systems.

A **DeviceNet NMEA 2000** cable and T-Piece connector are required. The T-Piece connector must be connected inline with the existing **NMEA 2000** bus and the cable should be connected to the T-Piece and the **DeviceNet** connector on the ECI-100.

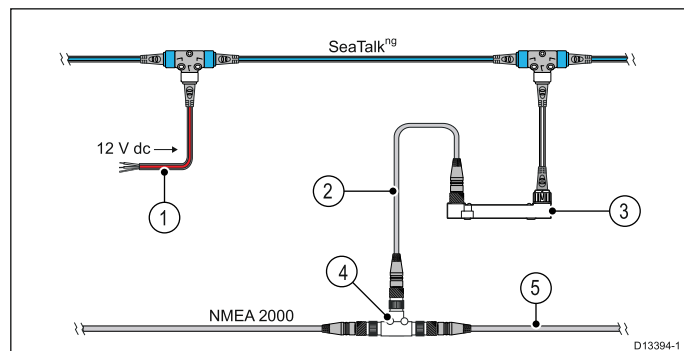

1. **SeaTalkng®** backbone power supply (12 V dc)
2. **DeviceNet NMEA 2000** cable
3. **ECI-100** unit
4. **DeviceNet NMEA 2000** T-Piece connector
5. **NMEA 2000** engine system bus

Note: DeviceNet cables and accessories are available from your local Marine electronics Dealer / Retailer.

Compatible Honda systems

Note: Please ensure you have compatible engine pre-installed with a **NMEA 2000** system fitted to your vessel before installing your **ECI-100**. Check with your local engine dealer if you are unsure.

Engine data only

BF50D	BF140D
BF60D	BF150A
BF80	BF200AKI
BF100	BF225A
BF115D	BFP60A
BF135A	

Honda engine data

With the ECI-100 connected to a compatible Honda engine system the following engine data can be displayed on a LightHouse™ MFD.

Engine Data

Engine Speed (RPM)	Engine Fuel Flow Rate
Engine Hours	Engine Boost Pressure
Engine Oil Temperature	Battery Voltage
Engine Coolant Temperature	Transmission Oil Pressure
Engine Oil Pressure	Transmission Oil Temperature
Engine Coolant Pressure	Fuel Level

Engine Alarms

Over Temperature	Low Coolant Level
Low Oil Pressure	Water In Fuel
Low Oil Level	

4.8 Caterpillar (CAT) engine connections

The **ECI-100** can connect to compatible Caterpillar engine systems.

The Caterpillar Y-Loom cable (E70305) is required.

Disconnect the existing Deutsch connector from the rear of the MPD, connect the Deutsch connectors on the Y-Loom cable to the rear of the MPD and to the cable that was just disconnected from the MPD. Finally connect the **DeviceNet** end of the Y-Loom cable to the **DeviceNet** connector on the **ECI-100**.

Single engine connection

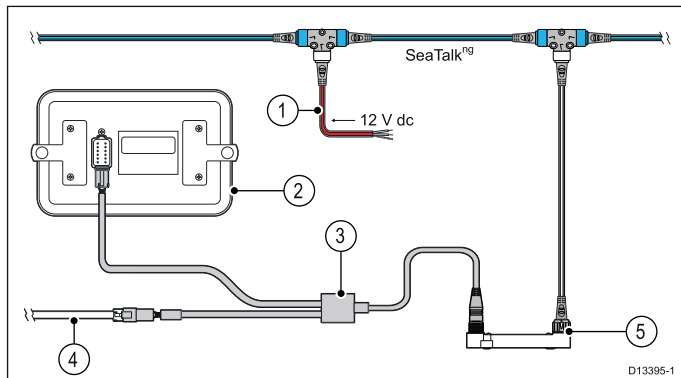

1. **SeaTalkng®** backbone power supply (12 V dc)
2. CAT MPD
3. Caterpillar Y-Loom cable (E70305)
4. Caterpillar engine system bus (previously connected to the MPD)
5. **ECI-100** unit

Note:

Multi-engine connection

An **ECI-100** and Y-Loom cable is required for each engine/MPD.

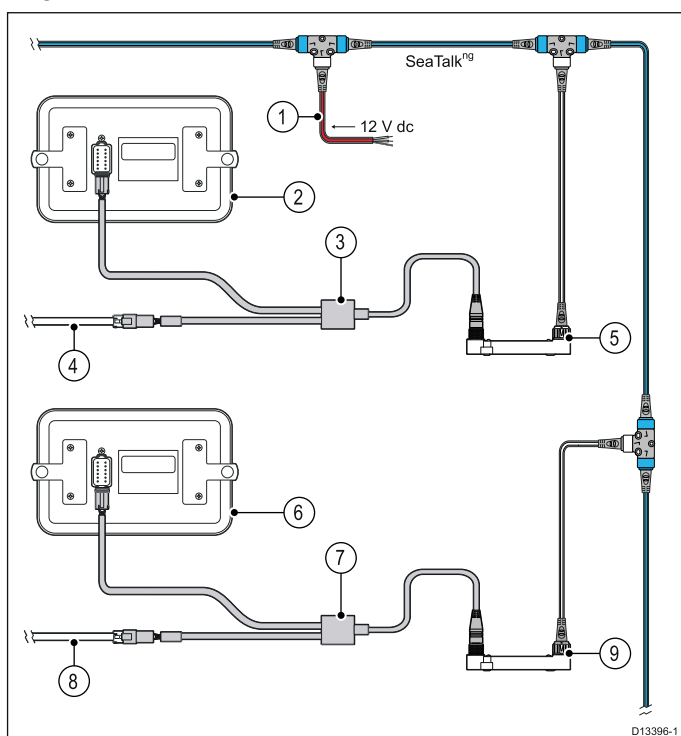

1. **SeaTalkng®** backbone power supply (12 V dc)

2. Engine 1 — CAT MPD
3. Engine 1— Caterpillar Y-Loom cable (E70305)
4. Engine 1 — Caterpillar engine system bus (previously connected to the MPD)
5. Engine 1 — **ECI-100** unit
6. Engine 2— CAT MPD
7. Engine 2— Caterpillar Y-Loom cable (E70305)
8. Engine 2— Caterpillar engine system bus (previously connected to the MPD)
9. Engine 2— **ECI-100** unit

Compatible Caterpillar systems

Compatible systems

CAT engine systems that include the following dedicated Marine Power Displays (MPD) are compatible:

- **Color MPD** (compatible with CAT electronically controlled marine engines from the C7 to 3500C Series)
- **MPD** (Compatible with CAT 3126B to 3500B Series engines)
- **Mini MPD**

Each CAT engine must have a dedicated MPD, engines without a dedicated MPD are not supported.

Note: The CAT Messenger display is not supported.

Caterpillar engine data

With the **ECI-100** connected to a compatible CAT engine system the following engine data can be displayed on a **LightHouse™** MFD.

Engine Data

Engine Speed (RPM)	Engine Fuel Pressure
Engine % Load	Engine Fuel Flow Rate
Engine Hours	Engine Boost Pressure
Engine Oil Temperature	Battery Voltage
Engine Coolant Temperature	Transmission Oil Temperature
Engine Oil Pressure	Transmission Oil Pressure
Engine Coolant Pressure	Fuel Level
Transmission Gear Position	

Engine Alarms

High Coolant Temperature	Low Coolant Level
Low Oil Pressure	High Boost Pressure
Low Oil Level	Engine Over Speed
Low Fuel Pressure	High Transmission Oil Temperature
Low Battery Voltage	Low Transmission Oil Pressure

Chapter 5: Mounting

Chapter contents

- [5.1 Mounting the unit on page 32](#)



5.1 Mounting the unit

The ECI is designed to be surface mounted.

Before mounting the unit ensure that you have:

- Identified the routes that the cables will take.

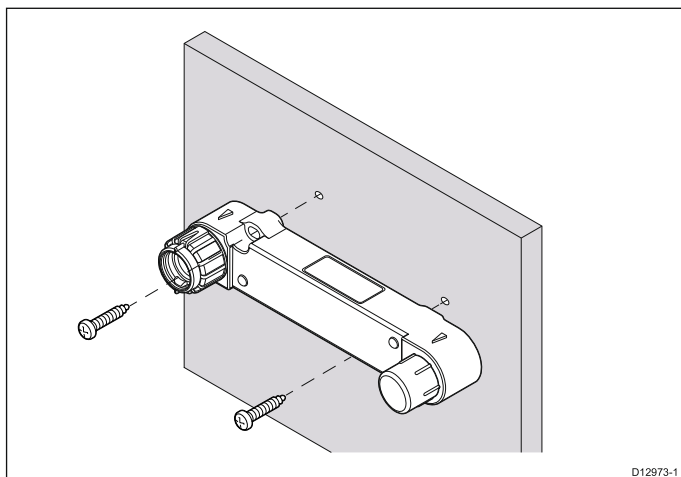

1. Switch off the vessel's power supply.
2. Check the selected location for the unit, a clear, flat area is required, which is safe to have screws fitted to.
3. Position the converter against the selected location and mark the surface through the converter's mounting holes.
4. Using an appropriate size drill bit, drill 2 holes at the marked locations.
5. Position the converter so that the mounting holes of the unit line up with the drilled holes in the mounting surface.
6. Using the fixings provided secure the converter to the mounting surface. Do NOT overtighten the fixings.
7. Connect the SeaTalk^{ng} spur cable and the DeviceNet adaptor cable to the unit.
8. Ensure the CAN bus connector of the DeviceNet adaptor cable is plugged into the relevant point on the engine's CAN bus.
9. Switch the vessel's power supply back on and check system.

Chapter 6: System checks and troubleshooting

Chapter contents

- 6.1 Initial power on test on page 34
- 6.2 Engine identification and setup - **LightHouse™** MFDs on page 35
- 6.3 Engine identification and setup — Legacy MFDs and Instrument Displays on page 37
- 6.4 Troubleshooting on page 39



6.1 Initial power on test

Once your product is fully connected and installed, perform an initial power on test to verify correct operation.

1. Switch on the vessel's power supply.
2. Switch on the vessel's engine(s).

The engine(s) has to be on and providing power to its CAN bus in order for both LEDs to function.

3. Look at the diagnostics LEDs.
 - During power up the LEDs will be illuminated red (power up usually takes approximately 6 seconds).
 - During normal operation the LED should flash green once every 15 seconds.
4. If the LED flashes in a different sequence, refer to the LED Diagnostics section for details.



6.2 Engine identification and setup - LightHouse™ MFDs

Engine identification

Engine data can be displayed on your MFD using the Data application, which provides some preset Engine pages for displaying some of the most common types of engine data.

Important: Before you can display Engine data on your MFD, you must:

- Ensure that your MFD is running LightHouse software version 8 or later.
- **Refer to the important “Engine setup with an ECI interface” and “Using the engine identification wizard” information.**
- Make the data connections, according to the instructions provided in the **87202 ECI Installation instructions**.
- Ensure all data buses are powered up (including engine data CAN buses, gateways, and also the SeaTalk^{ng} bus).
- Start the engine. It is important that only one engine is running at a time, to ensure that the system can isolate the correct engine data message.
- Run the **Engine identification wizard** to ensure that your engines are displayed in the correct order in the Data application.



Engine setup with an ECI interface

Before you can display engine data on your MFD, you may need to use the "Engine Identification wizard" on the MFD to setup the engines.

Important: When setting up on a multiple engine system, engines should always be turned on in sequence from port to starboard.

The following table details the different types of engine supported by the ECI interface unit, and the setup requirements for each:

Engine CAN bus protocol	Number of engines	Engine CAN bus configuration	Number of ECI units	Setup via wizard on MFD required
NMEA 2000	1	Single CAN bus	1	✗
NMEA 2000	2+	Single shared CAN bus	1	✗
NMEA 2000	2+	Separate CAN bus for each engine	1 for each CAN bus	✓
J1939	1	Single CAN bus	1	✗
J1939	2+	Single shared CAN bus	1	✗
J1939	2+	Separate CAN bus for each engine	1 for each CAN bus	✓

Using the engine identification wizard

If your engine data appears in the wrong order on the engine data pages you can correct this by running the engine identification wizard.

From the Homescreen:

1. Select **Set-up > System Settings > External Devices > Engines Set-up**.
2. If required change the number of engines your vessel has by selecting **Num. of Engines:** and entering the correct number of engines.

You can select up to 5 engines.

3. Select **Identify engines**.

Important: It is important that only one engine is running at a time, to ensure that the system can isolate the correct engine data message.

4. Follow the onscreen prompts to complete the engine identification wizard.

The engines that will be included in the identification wizard are determined by the Number of engines set during step 2 above.

- i. Switch Off ALL vessel engines and select **Next**.

The wizard will run through all engines (max of 5 as defined in step 2 above) from port to starboard in sequence.

- ii. Turn On the **port engine** and select **OK**.
The wizard will now listen for data and assign the engine instance as the port engine.
- iii. Turn On the **center port engine** and select **OK**.
The wizard will now listen for data and assign the engine instance as the center port engine.
- iv. Turn On the **center engine** and select **OK**.
The wizard will now listen for data and assign the engine instance as the center engine.

- v. Turn On the **center starboard engine** and select **OK**.

The wizard will now listen for data and assign the engine instance as the center starboard engine.

- vi. Turn On the **starboard engine** and select **OK**.
The wizard will now listen for data and assign the engine instance as the starboard engine.

5. Select **OK** on the Identify Engines confirmation dialog.

The engines will now appear in the correct location on the engine data page.

6.3 Engine identification and setup — Legacy MFDs and Instrument Displays

Engine identification — legacy MFDs and Instrument Displays

Before attempting to display engine data on legacy MFDs or compatible Instrument displays, it is recommended that you refer to your engine representative / dealer in the first instance. For your information, the basic procedure for displaying engine data on a legacy MFD or Instrument Display is detailed below.

Important: You must:

- Ensure that your MFD / Instrument Display is running the latest software version. Refer to www.raymarine.com/software/ to download the latest software.
- For engines with a **NMEA 2000** CAN bus, ensure that the CAN bus is outputting the relevant PGN messages that include the engine instance data. If in doubt, please contact your engine dealer.
- Only specific engine configurations are currently supported by legacy MFDs and Instrument Displays.
- Make the data connections, according to the instructions provided with your product.
- Ensure all data buses are powered up (including all engine CAN data buses, gateways, and also the **SeaTalk^{ng}** bus).
- Start the engine. Ensure that you follow any applicable sequencing rules, as specified in the “**Engine instancing and setup**” information.
- Select the “Engine Data Page” on your MFD / Instrument Display and ensure that the engine data is displayed correctly. You may need to configure a custom data page containing a specific arrangement of data dials. Refer to your MFD / Instrument Display manual for more information on how to do this.

Legacy MFD Example



Engine instancing and setup — legacy MFDs and Instrument Displays

Before you can display engine data on your legacy MFD or a compatible Instrument Display, your engine(s) may require "instancing" (assigned a unique ID / address) by an engine representative / dealer.

Single engine installations

Engine instancing is NOT required for single engine vessels.

Multiple engine installations

Legacy MFDs and Instrument Displays include have limited support for multiple engine installations.

The following table details the different types of engine supported, and the instancing requirements for each.

Engine CAN bus protocol	Number of engines	Engine CAN bus configuration	Number of ECI units	Start up Engines in sequence?	Instancing by Engine dealer required?
NMEA 2000	1	Single CAN bus	1	Only 1 engine to start up — sequence not applicable.	Not required.
NMEA 2000	2+	Single shared CAN bus	1	Start and stop each engine in sequence, from port through to starboard.	Instancing may be required. Contact your Engine dealer.
NMEA 2000	2+	Separate CAN bus for each engine	This engine configuration is NOT currently supported or recommended. A current generation LightHouse™ MFD is required.		
J1939	1	Single CAN bus	1	Only 1 engine to start up — sequence not applicable.	Not required.
J1939	2+	Single shared CAN bus	1	Start and stop each engine in sequence, from port through to starboard.	Not required.
J1939	2+	Separate CAN bus for each engine	This engine configuration is NOT currently supported or recommended. A current generation LightHouse™ MFD is required.		

6.4 Troubleshooting

The troubleshooting information provides possible causes and corrective action required for common problems associated with marine electronics installations.

All Raymarine products are, prior to packing and shipping, subjected to comprehensive test and quality assurance programs. However, if you experience problems with the operation of your product this section will help you to diagnose and correct problems in order to restore normal operation.

If after referring to this section you are still having problems with your unit, please contact Raymarine Technical Support for further advice.



Power up troubleshooting

Product does not turn on or keeps turning off

Possible causes	Possible solutions
Blown fuse / tripped breaker	<ol style="list-style-type: none"> 1. Check condition of relevant fuses and breakers and connections, replace if necessary (Refer to Chapter 9 Technical specification for fuse ratings.) 2. If fuse keeps blowing check for cable damage, broken connector pins or incorrect wiring.
Poor / damaged / insecure power supply cable / connections	<ol style="list-style-type: none"> 1. Check the unit's connector for broken or bent pins. 2. Check that the cable connector is fully inserted into the unit and that the locking collar is in the locked position. 3. Check the power supply cable and connectors for signs of damage or corrosion, replace if necessary. 4. With the unit turned on, try flexing the power cable near to the display connector to see if this causes the unit to re-boot/loose power, replace if necessary. 5. Check the vessel's battery voltage, the condition of the battery terminals and power supply cables, ensuring connections are secure, clean and free from corrosion, replace if necessary. 6. With the product under load, using a multi-meter, check for high voltage drop across all connectors/fuses etc (this can cause the Fishfinder applications to stop scrolling or the unit to reset/turn off), replace if necessary.
Incorrect power connection	The power supply may be wired incorrectly, ensure the installation instructions have been followed. (Refer to Chapter 4 Cables and connections for cable and connection requirements.)
Power source insufficient	With the product under load, using a multi-meter, check the power supply voltage as close to the unit as possible to establish actual voltage when the current is flowing. (Refer to Chapter 9 Technical specification for power supply requirements.)

Product will not boot up (re-boot loop)

Possible causes	Possible solutions
Power supply and connection	See possible solutions from 'Products does not turn on or keeps turning off' above.
Software corruption	<ol style="list-style-type: none"> 1. In the unlikely event that the products software has become corrupted please try re-flashing the latest software from the Raymarine website. 2. On display products, as a last resort, you can try to perform a 'Power on Reset', however this will delete all settings/presets and user data (such as waypoints and tracks) and revert the unit back to factory defaults.

ECI-100 troubleshooting



Aspects of the installation can cause problems with the data shared between connected equipment. Such problems, their possible causes and solutions are described here.

Missing or no engine data is displayed on MFD

Possible causes	Possible solutions
ECI-100 not powered or not powered correctly.	<p>Refer to the 'Power up troubleshooting' section for details.</p> <ul style="list-style-type: none"> • Ensure that the SeaTalk^{ng} backbone is correctly powered. • Ensure that the engine CAN bus is powered on. <div style="border: 1px solid black; padding: 5px; margin-top: 10px;"> <p>Note: The ECI-100 requires power from both the SeaTalk^{ng} backbone and the Engine CAN bus.</p> </div>
Engine or engine data item not supported	Only the specified data items on compatible engines can be displayed.
MFD not configured with correct number of engines	<p>Re-configure MFD to ensure correct number of engines has been selected:</p> <ul style="list-style-type: none"> • Legacy MFDs — From the Engine monitor / application select: Menu > Panel Setup Menu > Number of Engines • LightHouse™ powered MFDs — From the Homescreen select: Customize > Boat Details > Num. of Engines
Engine identification wizard not completed (LightHouse™ MFD)	Complete the Engine identification wizard.
Legacy MFDs may not support all PGNs	Upgrade MFD to an a, c, e, eS or gS Series to ensure
MFD software not compatible with ECI-100	Upgrade MFD software to the latest version available from the website.
ECI-100 running older software	Upgrade ECI-100 software to the latest version available from the website.
ECI-100 is in instancing mode. The ECI-100 will not output data until it has finished instancing the engines.	<ul style="list-style-type: none"> • Wait until engine instancing has completed. • Engine instancing may be required, please contact your engine dealer.
Engine configuration requires multiple ECI-100 units.	On some, multiple engine configurations, where each engine is on its own CAN bus you must use 1 ECI-100 unit for each engine CAN bus.
Engine not compatible with ECI-100	Check the Raymarine website for a list of compatible engines.
Incompatible 3rd party Engine Gateway present on system	Remove 3rd party Engine Gateway and try again.
ECI-100 has previously been used on a system with a different engine type.	<ul style="list-style-type: none"> • Contact Technical Support for information on how to get your ECI-100 reset. • Swap out ECI-100 for new unit.

LED indications

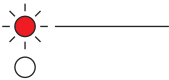
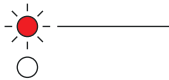
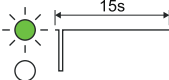
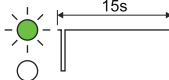
This product contains 2 diagnostic LEDs, one for the SeaTalk^{ng} connection and one for the engine CAN bus connection. The LEDs for this product flash (blink) in set sequences which provides information on the current status of the unit for diagnostics and troubleshooting purposes.

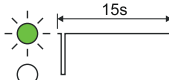
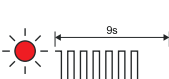
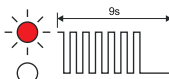
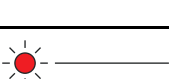
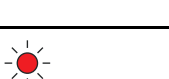
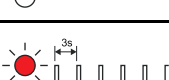
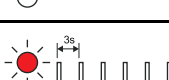
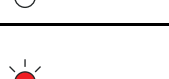
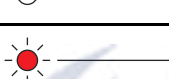
LED color	SeaTalk ^{ng} LED code	Engine CAN bus LED code	State	User action
Red			Powering up	None (normal power up takes approximately 6 seconds.)
Green			Normal operation	None
Green			DeviceNet powered on, SeaTalk ^{ng} powered off	Power up SeaTalk ^{ng} network.
Red			Network connected but no traffic (no message received in more than 5 seconds.)	
Red			SeaTalk ^{ng} powered on, DeviceNet Off.	
Red			General error (Device connected wrong way round)	Swap over SeaTalk ^{ng} and DeviceNet connections
Red			Software download in progress (longer than 6 seconds.)	Wait for download to complete — Multifunction display will indicate when software download is completed.

Note: If any other LED sequence other than described above is seen and persists please contact Raymarine technical support.

Resetting the ECI-100

A specialist tool is required to reset the ECI-100, contact Raymarine Product Support for further information.

Your ECI-100 will need resetting if it has previously been used on a different engine type.

Chapter 7: Maintenance

Chapter contents

- 7.1 Routine checks on page 44
- 7.2 Unit cleaning instructions on page 44



7.1 Routine checks

The following periodic checks should be made:

- Examine cables for signs of damage, such as chafing, cuts or nicks.
- Check that the cable connectors are firmly attached and that their locking mechanisms are properly engaged.

Note: Cable checks should be carried out with the power supply switched off.

7.2 Unit cleaning instructions

The unit does not require regular cleaning. However, if you find it necessary to clean the unit, please follow the steps below:

1. Ensure power is switched off.
2. Wipe unit clean with a damp cloth.
3. If necessary, use a mild detergent solution to remove grease marks.



Chapter 8: Technical support

Chapter contents

- [8.1 Raymarine product support and servicing on page 46](#)
- [8.2 Viewing product information on page 47](#)



8.1 Raymarine product support and servicing

Raymarine provides a comprehensive product support service, as well as warranty, service, and repairs. You can access these services through the Raymarine website, telephone, and e-mail.

Product information

If you need to request service or support, please have the following information to hand:

- Product name.
- Product identity.
- Serial number.
- Software application version.
- System diagrams.

You can obtain this product information using the menus within your product.

Servicing and warranty

Raymarine offers dedicated service departments for warranty, service, and repairs.

Don't forget to visit the Raymarine website to register your product for extended warranty benefits: <http://www.raymarine.co.uk/display/?id=788>.

Region	Tele- phone	E-mail
United Kingdom (UK), EMEA, and Asia Pacific	+44 (0)1329 246 932	emea.service@raymarine.com
United States (US)	+1 (603) 324 7900	rm-usrepair@flir.com

Web support

Please visit the "Support" area of the Raymarine website for:

- **Manuals and Documents** — <http://www.raymarine.co.uk/display/?id=10125>
- **FAQ / Knowledgebase** — <http://www.raymarine.co.uk/knowledgebase/>
- **Technical support forum** — <http://raymarine.ning.com/>
- **Software updates** — <http://www.raymarine.com/software>

Telephone and e-mail support

Region	Tele- phone	E-mail
United Kingdom (UK), EMEA, and Asia Pacific	+44 (0)1329 246 777	support.uk@raymarine.com
United States (US)	+1 (603) 324 7900 (Toll-free: +800 539 5539)	support@raymarine.com

Region	Tele- phone	E-mail
Australia and New Zealand	+61 2 8977 0300	aus.support@raymarine.com (Raymarine subsidiary)
France	+33 (0)1 46 49 72 30	support.fr@raymarine.com (Raymarine subsidiary)
Germany	+49 (0)40 237 808 0	support.de@raymarine.com (Raymarine subsidiary)
Italy	+39 02 9945 1001	support.it@raymarine.com (Raymarine subsidiary)
Spain	+34 96 2965 102	sat@azimut.es (Authorized Raymarine distributor)
Netherlands	+31 (0)26 3614 905	support.nl@raymarine.com (Raymarine subsidiary)
Sweden	+46 (0)317 633 670	support.se@raymarine.com (Raymarine subsidiary)
Finland	+358 (0)207 619 937	support.fi@raymarine.com (Raymarine subsidiary)
Norway	+47 692 64 600	support.no@raymarine.com (Raymarine subsidiary)
Denmark	+45 437 164 64	support.dk@raymarine.com (Raymarine subsidiary)
Russia	+7 495 788 0508	info@mikstmarine.ru (Authorized Raymarine distributor)

8.2 Viewing product information

You can view information about your unit from the **Diagnostics** menu on a compatible multifunction display. This option displays information such as product serial number and software version.

With the Homescreen displayed:

1. Select **Set-up**.
2. Select **Maintenance**.
3. Select **Diagnostics**.
4. Select the **Select Device** option.
A list of connected devices is displayed.
5. Select the product for which you want to view information. Alternatively, select **Show All Data** to display information for all connected products.





Chapter 9: Technical specification

Chapter contents

- [9.1 Technical specification on page 50](#)



9.1 Technical specification

Physical specification

Dimensions	<ul style="list-style-type: none">• Length: 109.2 mm (4.3 in)• Height: 30.2 mm (1.19 in)• Width: 21.35 mm (0.84 in)
Weight	43 g (1.52 oz)

Power specification

	SeaTalk^{ng}	Engine CAN bus (DeviceNet)
Nominal supply voltage	12 V dc	12 to 24 V dc
Operating voltage range	10.8 V to 16 V dc	10.8 V dc to 31.2 V dc
Current	12 mA	<ul style="list-style-type: none">• 12V — 12.5 mA• 24V — 11 mA
Load Equivalency Number (LEN)	1	N/A

Environmental specification

Operating temperature	-20°C to +55°C (+4°F to +131°F)
Storage temperature	-30°C to +70°C (-22°F to +158°F)
Relative humidity	95%
Waterproof rating	IPX6 and IPX7

Conformance specification

Conformance	<ul style="list-style-type: none">• EN 60945:2002• EMC Directive 2004/108/EC• Australia and New Zealand: C-Tick, Compliance Level 2
--------------------	---

Chapter 10: Spares and accessories

Chapter contents

- [10.1 Spares and accessories on page 52](#)
- [10.2 SeaTalk^{ng}® cables and accessories on page 52](#)



10.1 Spares and accessories

Engine specific link cables

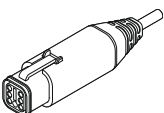
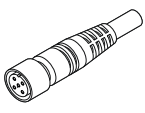
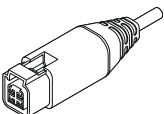
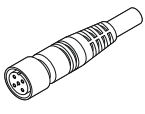
Description	Engine connector	ECI-100 connector	Part number
Volvo EVC link cable – 1 m (3.3 ft)			E70240
Yamaha Command Link Plus cable – 1 m (3.3 ft)			E70242

Y Loom cables

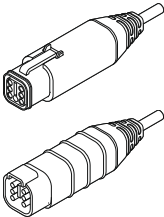
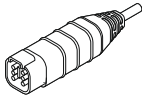
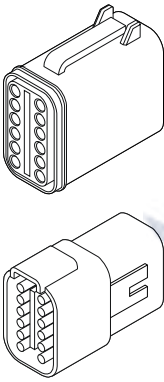
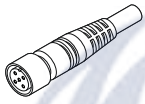
Description	Engine connectors	Adaptor cable / ECI-100 connector	Part number
Volvo Y-Loom cable – 1 m (3.3 ft) / 500 mm (1.5 ft)			E70241
Caterpillar Y-Loom cable – 1 m (3.3 ft) / 500 mm (1.5 ft)			E70305

10.2 SeaTalk^{ng}® cables and accessories

SeaTalk^{ng} cables and accessories for use with compatible products.

Description	Part No	Notes
SeaTalk ^{ng} starter kit	T70134	Includes: <ul style="list-style-type: none"> • 1 x 5 Way connector (A06064) • 2 x Backbone terminator (A06031) • 1 x 3 m (9.8 ft) spur cable (A06040) • 1 x Power cable (A06049)
SeaTalk ^{ng} Backbone Kit	A25062	Includes: <ul style="list-style-type: none"> • 2 x 5 m (16.4 ft) Backbone cable (A06036) • 1 x 20 m (65.6 ft) Backbone cable (A06037) • 4 x T-piece (A06028) • 2 x Backbone terminator (A06031) • 1 x Power cable (A06049)
SeaTalk ^{ng} 0.4 m (1.3 ft) spur	A06038	
SeaTalk ^{ng} 1 m (3.3 ft) spur	A06039	
SeaTalk ^{ng} 3 m (9.8 ft) spur	A06040	
SeaTalk ^{ng} 5 m (16.4 ft) spur	A06041	
SeaTalk ^{ng} 0.4 m (1.3 ft) elbow spur	A06042	
SeaTalk ^{ng} 0.4 m (1.3 ft) backbone	A06033	
SeaTalk ^{ng} 1 m (3.3 ft) backbone	A06034	
SeaTalk ^{ng} 3 m (9.8 ft) backbone	A06035	
SeaTalk ^{ng} 5 m (16.4 ft) backbone	A06036	
SeaTalk ^{ng} 9 m (29.5 ft) backbone	A06068	
SeaTalk ^{ng} 20 m (65.6 ft) backbone	A06037	
SeaTalk ^{ng} to bare ends 1 m (3.3 ft) spur	A06043	

Description	Part No	Notes
SeaTalk ^{ng} to bare ends 3 m (9.8 ft) spur	A06044	
SeaTalk ^{ng} Power cable	A06049	
SeaTalk ^{ng} Terminator	A06031	
SeaTalk ^{ng} T-piece	A06028	Provides 1 x spur connection
SeaTalk ^{ng} 5-way connector	A06064	Provides 3 x spur connections
SeaTalk ^{ng} backbone extender	A06030	
SeaTalk to SeaTalk ^{ng} converter kit	E22158	Allows the connection of SeaTalk devices to a SeaTalk ^{ng} system.
SeaTalk ^{ng} Inline terminator	A80001	Provides direct connection of a spur cable to the end of a backbone cable. No T-piece required.
SeaTalk ^{ng} Blanking plug	A06032	
ACU / SPX SeaTalk ^{ng} spur cable 0.3 m (1.0 ft)	R12112	Connects an SPX course computer or an ACU to a SeaTalk ^{ng} backbone.
SeaTalk (3 pin) to SeaTalk ^{ng} adaptor cable 0.4 m (1.3 ft)	A06047	
SeaTalk to SeaTalk ^{ng} spur 1 m (3.3 ft) spur	A22164	
SeaTalk2 (5 pin) to SeaTalk ^{ng} adaptor cable 0.4 m (1.3 ft)	A06048	
DeviceNet adaptor cable (Female)	A06045	Allows the connection of NMEA 2000 devices to a SeaTalk ^{ng} system.
DeviceNet adaptor cable (Male)	A06046	Allows the connection of NMEA 2000 devices to a SeaTalk ^{ng} system.
DeviceNet adaptor cable (Female) to bare ends.	E05026	Allows the connection of NMEA 2000 devices to a SeaTalk ^{ng} system.
DeviceNet adaptor cable (Male) to bare ends.	E05027	Allows the connection of NMEA 2000 devices to a SeaTalk ^{ng} system.

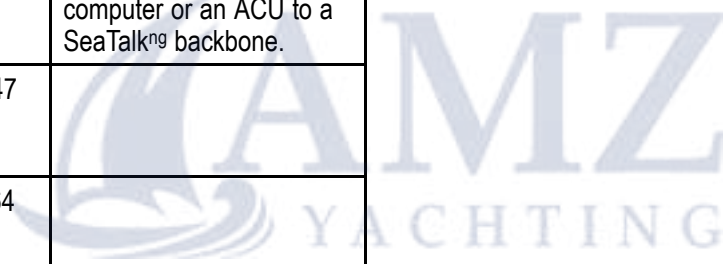



Appendix A Supported J1939 and NMEA 2000 sentences

Engine (J1939 and NMEA 2000) to SeaTalk^{ng}® (NMEA 2000)

The tables below show standard **J1939** parameters and **NMEA 2000** PGNs that can be sent from a connected engine, received by the **ECI-100**, bridged and transmitted onto the **SeaTalk^{ng}®** bus.

Note: Please refer to the manufacturer specific, engine data tables found in [Chapter 4 Cables and connections](#) for specific, supported engine data details.

Engine Parameter	Received from engine bus		Transmitted (ECI-100 to SeaTalk ^{ng} ® bus)
	J1939	NMEA 2000	NMEA 2000
Engine Speed	61444	127488	127488
Engine Hours (run time)	65253	127489	127489
Engine Oil Temperature	65262	127489	127489
Engine Coolant Temperature	65262	127489	127489
Engine Oil Pressure	65263	127489	127489
Engine Coolant Pressure	65263	127489	127489
Engine Fuel Delivery Pressure	65263	127489	127489
Engine Fuel Rate	65266	127489	127489
Engine Boost Pressure	65270	127488	127488
Battery Voltage (Alternator potential)	65271	127489 / 127508	127489 / 127508
Transmission Oil Pressure	65272	127493	127493
Transmission Oil Temperature	65272	127493	127493
Fuel Tank Level	65276	127505	127505
Vehicle Direction/Speed	65256	127250	127250
Power Trim Position	65373	127488	127488

Engine Parameter	Received from engine bus		Transmitted (ECI-100 to SeaTalk ^{ng} ® bus)
	J1939	NMEA 2000	NMEA 2000
Throttle Position Sensor		127489	127489
Engine Percent Load	61443	127489	127489
Transmission Gear	61445	127493	127493
Rudder Position		127245	127245
Speed		128259	128259
Depth		128267	128267
Water Temperature		130310	130310
COG/SOG		129026 / 129029	129026 / 129029

Alarms

Engine Parameter	Received from engine bus		Transmitted (ECI-100 to SeaTalk ^{ng} ® bus)
	J1939	NMEA 2000	NMEA 2000
High Coolant Temperature	65226	127489	127489
Low Oil Pressure	65226	127489	127489
Low Oil Level	65226	127489	127489
Low Battery Voltage	65226	127489	127489
Low Coolant Level	65226	127489	127489
Water in Fuel		127489	127489
Check engine		127489	127489
Low Fuel Pressure	65226	127489	127489
Engine over speed (Over Revving)	65226	127489	127489
High Boost Pressure	65226	127489	127489
High Transmission Oil Temperature	65226	127493	127493
Low Transmission Oil Pressure	65226	127493	127493







www.raymarine.com

